

RS485 MODBUS Module 16I-M

Expansion Module – 16 digital inputs with counters memory

Version 2.0 — 12/02/2013

User Manual



S&AAR
Solutions For Automation & Robotics

Manufactured for

aspar



- 5.
- 6.
- 7.
- 8.
- 9.
- 10.
- 11.

Thank you for choosing our product.

This manual will help you with proper support and proper operation of the device.

The information contained in this manual have been prepared with utmost care by our professionals and serve as a description of the product without incurring any liability for the purposes of commercial law.

This information does not release you from the obligation of own judgment and verification.

We reserve the right to change product specifications without notice.

Please read the instructions carefully and follow the recommendations contained therein.



WARNING!

Failure to follow instructions can result in equipment damage or impede the use of the hardware or software.

12. Safety rules

- Before first use, refer to this manual
- Before first use, make sure that all cables are connected properly
- Please ensure proper working conditions, according to the device specifications (eg: supply voltage, temperature, maximum power consumption)
- Before making any modifications to wiring connections, turn off the power supply

13. Module Features

13.1.

Purpose and description of the module

16I Module is an innovative device that provides a simple and cost-effective extension of the number of lines of input in popular PLCs.

The module has 16 digital inputs with configurable timer/counter option. In addition, terminals IN1 and IN2 and IN3 and IN4 can be used to connect two encoders. All inputs and outputs are isolated from the logic of using optocouplers. Each channel can be individually configured in one of several modes.

The module has a fast non-volatile FRAM memory that stores values of the counters and the counters captured. This means that even after a power failure, these values are stored and can further use when the power returns.

This module is connected to the RS485 bus with twisted-pair wire. Communication is via MODBUS RTU or MODBUS ASCII. The use of 32-bit ARM core processor provides fast processing and quick communication. The baud rate is configurable from 2400 to 115200.

The module is designed for mounting on a DIN rail in accordance with DIN EN 5002.

The module is equipped with a set of LEDs used to indicate the status of inputs and outputs useful for diagnostic purposes and helping to find errors.

Module configuration is done via USB by using a dedicated computer program. You can also change the parameters using the MODBUS protocol.

13.2.

Technical Specifications

Power Supply	Voltage	12-24 V DC \pm 20%
	Maximum Current*	60 mA @ 12V / 40 mA @ 24V
Digital Inputs	No of inputs	16
	Voltage range	0 – 36V
	Low State „0”	0 – 3V
	High State „1”	6 – 36V
	Input impedance	4k Ω
	Isolation	1500 Vrms
	Input Type	PNP or NPN
Counters	No	16
	Resolution	32 bits
	Frequency	1kHz (max)
	Impulse Width	500 μ s (min)
Temperature	Work	-10 °C - +50°C
	Storage	-40 °C - +85°C
Connectors	Power Supply	2 pin
	Communication	3 pin
	Inputs	2 x 10 pin
	Configuration	Mini USB
Size	Height	120 mm
	Length	101 mm
	Width	22,5 mm
Interface	RS485	Up to 128 devices

* Maximum current with active Modbus transmission and high state on all inputs

13.3.***Dimensions of the product***

Look and dimensions of the module are shown below. The module is mounted directly to the rail in the DIN industry standard. Power connectors, communication and IOs are at the bottom and top of the module. USB connector configuration and indicators located on the front of the module.

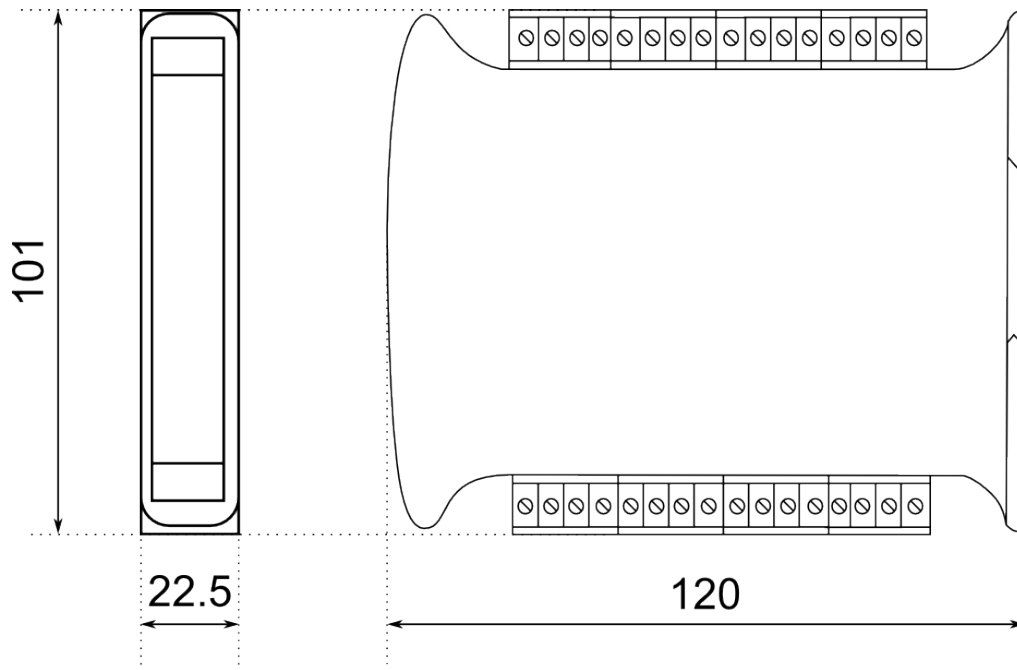

14. Communication configuration

14.1. *Grounding and shielding*

In most cases, IO modules will be installed in an enclosure along with other devices which generate electromagnetic radiation. Examples of these devices are relays and contactors, transformers, motor controllers etc. This electromagnetic radiation can induce electrical noise into both power and signal lines, as well as direct radiation into the module causing negative effects on the system. Appropriate grounding, shielding and other protective steps should be taken at the installation stage to prevent these effects. These protective steps include control cabinet grounding, module grounding, cable shield grounding, protective elements for electromagnetic switching devices, correct wiring as well as consideration of cable types and their cross sections.

14.2. *Network Termination*

Transmission line effects often present a problem on data communication networks. These problems include reflections and signal attenuation.

To eliminate the presence of reflections from the end of the cable, the cable must be terminated at both ends with a resistor across the line equal to its characteristic impedance. Both ends must be terminated since the direction of propagation is bi-directional. In the case of an RS485 twisted pair cable this termination is typically 120 Ω .

14.3. *Setting Module Address in RS485 Modbus Network*

The following table shows how to set switch to determine the address of the module. The module address is set with the switches in the range of 0 to 31. Addresses From 32 to 255 can be set via RS485 or USB.

Addr	SW5	SW4	SW3	SW2	SW1	Addr	SW5	SW4	SW3	SW2	SW1	Addr	SW5	SW4	SW3	SW2	SW1
0	OFF	OFF	OFF	OFF	OFF	11	OFF	ON	OFF	ON	ON	22	ON	OFF	ON	ON	OFF
1	OFF	OFF	OFF	OFF	ON	12	OFF	ON	ON	OFF	OFF	23	ON	OFF	ON	ON	ON
2	OFF	OFF	OFF	ON	OFF	13	OFF	ON	ON	OFF	ON	24	ON	ON	OFF	OFF	OFF
3	OFF	OFF	OFF	ON	ON	14	OFF	ON	ON	ON	OFF	25	ON	ON	OFF	OFF	ON
4	OFF	OFF	ON	OFF	OFF	15	OFF	ON	ON	ON	ON	26	ON	ON	OFF	ON	OFF
5	OFF	OFF	ON	OFF	ON	16	ON	OFF	OFF	OFF	OFF	27	ON	ON	OFF	ON	ON
6	OFF	OFF	ON	ON	OFF	17	ON	OFF	OFF	OFF	ON	28	ON	ON	ON	OFF	OFF
7	OFF	OFF	ON	ON	ON	18	ON	OFF	OFF	ON	OFF	29	ON	ON	ON	OFF	ON
8	OFF	ON	OFF	OFF	OFF	19	ON	OFF	OFF	ON	ON	30	ON	ON	ON	ON	OFF
9	OFF	ON	OFF	OFF	ON	20	ON	OFF	ON	OFF	OFF	31	ON	ON	ON	ON	ON
10	OFF	ON	OFF	ON	OFF	21	ON	OFF	ON	OFF	ON						

14.4.***Types of Modbus Registers***

There are 4 types of variables available in the module

Type	Beginning address	Variable	Access	Modbus Command
1	00001	Digital Outputs	Bit Read & Write	1, 5, 15
2	10001	Digital Inputs	Bit Read	2
3	30001	Input Registers	Registered Read	3
4	40001	Output Registers	Registered Read & Write	4, 6, 16

14.5.***Communication settings***

The data stored in the modules memory are in 16-bit registers. Access to registers is via MODBUS RTU or MODBUS ASCII.

14.5.1.**Default settings**

You can restore the default configuration by the switch SW6 (see 14.5.2 - Restore the default configuration)

Baud rate	19200
Parity	Nie
Data bits	8
Stop bits	1
Reply Delay [ms]	0
Modbus Type	RTU

14.5.2.**Restore the default configuration**

To restore the default configuration:

- turn off the power
- turn on the switch SW6
- turn on the power
- when power and communication LED flash turn off the switch SW6

Caution! After restoring the default configuration all values stored in the registers will be cleared as well.

14.5.3.

Configuration registers

Modbus	Dec	Hex	Name	Values
Address				
40003	2	0x02	Baud rate	0 – 2400 1 – 4800 2 – 9600 3 – 19200 4 – 38400 5 – 57600 6 – 115200 other – value * 10
40005	4	0x04	Parity	0 – none 1 – odd 2 – even 3 – always 1 4 – always 0
40004	3	0x03	Stop Bits LSB	1 – one stop bit 2 – two stop bits
40004	3	0x03	Data Bits MSB	7 – 7 data bits 8 – 8 data bits
40006	5	0x05	Response delay	Time in ms
40007	6	0x06	Modbus Mode	0 – RTU 1 – ASCII

15. Indicators

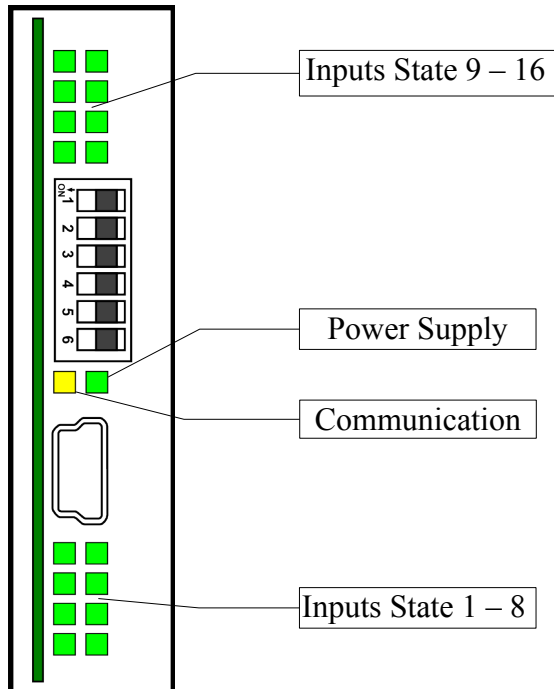

Indicator	Description
Power supply	LED indicates that the module is correctly powered.
Communication	The LED lights up when the unit received the correct packet and sends the answer.
Inputs state	LED indicates that on the input is high state.

16. Module Connection

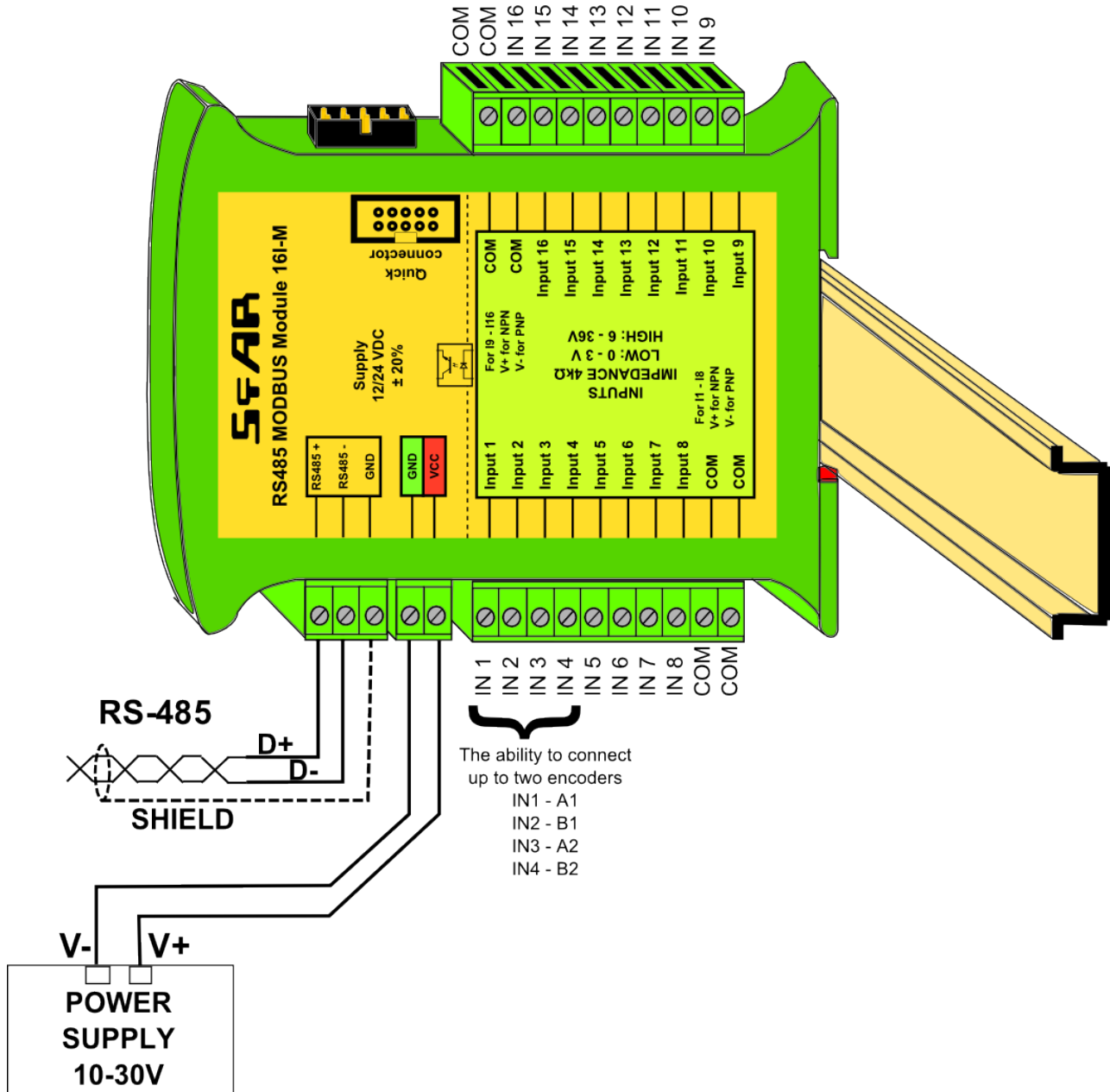

17. Switches

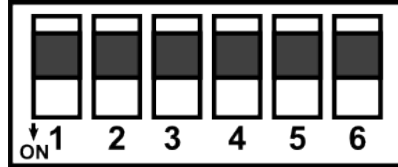

Switch	Function	Description
1	Module address +1	Setting module address from 0 to 31
2	Module address +2	
3	Module address +4	
4	Module address +8	
5	Module address +16	
6	Restoring default settings	Restoring default settings (see 14.5.1 - Default settings and 14.5.2 - Restore the default configuration).

18. Modules Registers

18.1. *Registered access*

Modbus	Dec	Hex	Register Name	Access	Description
30001	0	0x00	Version/Type	Read	Version and Type of the device
30002	1	0x01	Switches	Read	Switches state
40003	2	0x02	Baud rate	Read & Write	RS485 baud rate
40004	3	0x03	Stop Bits & Data Bits	Read & Write	No of Stop bits & Data Bits (see 14.5.3)
40005	4	0x04	Parity	Read & Write	Parity bit
40006	5	0x05	Response Delay	Read & Write	Response delay in ms
40007	6	0x06	Modbus Mode	Read & Write	Modbus Mode (ASCII or RTU)
40033	32	0x20	Received packets MSB	Read & Write	No of received packets
40034	33	0x21	Received packets LSB	Read & Write	
40035	34	0x22	Incorrect packets MSB	Read & Write	No of received packets with error
40036	35	0x23	Incorrect packets LSB	Read & Write	
40037	36	0x24	Sent packets MSB	Read & Write	No of sent packets
40038	37	0x25	Sent packets LSB	Read & Write	
30051	50	0x32	Inputs	Read	Inputs state
40053	52	0x34	Counter 1 MSB	Read & Write	32-bit counter 1 with memory
40054	53	0x35	Counter 1 LSB	Read & Write	
40054	54	0x36	Counter 2 MSB	Read & Write	32-bit counter 2 with memory
40056	55	0x37	Counter 2 LSB	Read & Write	
40057	56	0x38	Counter 3 MSB	Read & Write	32-bit counter 3 with memory
40058	57	0x39	Counter 3 LSB	Read & Write	
40059	58	0x3A	Counter 4 MSB	Read & Write	32-bit counter 4 with memory
40060	59	0x3B	Counter 4 LSB	Read & Write	
40061	60	0x3C	Counter 5 MSB	Read & Write	32-bit counter 5 with memory
40062	61	0x3D	Counter 5 LSB	Read & Write	
40063	62	0x3E	Counter 6 MSB	Read & Write	32-bit counter 6 with memory
40064	63	0x3F	Counter 6 LSB	Read & Write	
40065	64	0x40	Counter 7 MSB	Read & Write	32-bit counter 7 with memory
40066	65	0x41	Counter 7 LSB	Read & Write	
40067	66	0x42	Counter 8 MSB	Read & Write	32-bit counter 8 with memory
40068	67	0x43	Counter 8 LSB	Read & Write	
40069	68	0x44	Counter 9 MSB	Read & Write	32-bit counter 9 with memory
40070	69	0x45	Counter 9 LSB	Read & Write	
40071	70	0x46	Counter 10 MSB	Read & Write	32-bit counter 10 with memory

Modbus	Dec	Hex	Register Name	Access	Description
40072	71	0x47	Counter 10 LSB	Read & Write	32-bit counter 11 with memory
40073	72	0x48	Counter 11 MSB	Read & Write	
40074	73	0x49	Counter 11 LSB	Read & Write	
40075	74	0x4A	Counter 12 MSB	Read & Write	32-bit counter 12 with memory
40076	75	0x4B	Counter 12 LSB	Read & Write	
40077	76	0x4C	Counter 13 MSB	Read & Write	32-bit counter 13 with memory
40078	77	0x4D	Counter 13 LSB	Read & Write	
40079	78	0x4E	Counter 14 MSB	Read & Write	32-bit counter 14 with memory
40080	79	0x4F	Counter 14 LSB	Read & Write	
40081	80	0x50	Counter 15 MSB	Read & Write	32-bit counter 15 with memory
40082	81	0x51	Counter 15 LSB	Read & Write	
40083	82	0x52	Counter 16 MSB	Read & Write	32-bit counter 16 with memory
40084	83	0x53	Counter 16 LSB	Read & Write	
40085	84	0x54	CCounter 1 MSB	Read & Write	32-bit value of captured counter 1 with memory
40086	85	0x55	CCounter 1 LSB	Read & Write	
40087	86	0x56	CCounter 2 MSB	Read & Write	32-bit value of captured counter 2 with memory
40088	87	0x57	CCounter 2 LSB	Read & Write	
40089	88	0x58	CCounter 3 MSB	Read & Write	32-bit value of captured counter 3 with memory
40090	89	0x59	CCounter 3 LSB	Read & Write	
40091	90	0x5A	CCounter 4 MSB	Read & Write	32-bit value of captured counter 4 with memory
40092	91	0x5B	CCounter 4 LSB	Read & Write	
40093	92	0x5C	CCounter 5 MSB	Read & Write	32-bit value of captured counter 5 with memory
40094	93	0x5D	CCounter 5 LSB	Read & Write	
40095	94	0x5E	CCounter 6 MSB	Read & Write	32-bit value of captured counter 6 with memory
40096	95	0x5F	CCounter 6 LSB	Read & Write	
40097	96	0x60	CCounter 7 MSB	Read & Write	32-bit value of captured counter 7 with memory
40098	97	0x61	CCounter 7 LSB	Read & Write	
40099	98	0x62	CCounter 8 MSB	Read & Write	32-bit value of captured counter 8 with memory
40100	99	0x63	CCounter 8 LSB	Read & Write	
40101	100	0x64	CCounter 9 MSB	Read & Write	32-bit value of captured counter 9 with memory
40102	101	0x65	CCounter 9 LSB	Read & Write	
40103	102	0x66	CCounter 10 MSB	Read & Write	32-bit value of captured counter 10 with memory
40104	103	0x67	CCounter 10 LSB	Read & Write	
40105	104	0x68	CCounter 11 MSB	Read & Write	32-bit value of captured counter 11 with memory
40106	105	0x69	CCounter 11 LSB	Read & Write	

Modbus	Dec	Hex	Register Name	Access	Description
40107	106	0x6A	CCounter 12 MSB	Read & Write	32-bit value of captured counter 12 with memory
40108	107	0x6B	CCounter 12 LSB	Read & Write	
40109	108	0x6C	CCounter 13 MSB	Read & Write	32-bit value of captured counter 13 with memory
40110	109	0x6D	CCounter 13 LSB	Read & Write	
40111	110	0x6E	CCounter 14 MSB	Read & Write	32-bit value of captured counter 14 with memory
40112	111	0x6F	CCounter 14 LSB	Read & Write	
40113	112	0x70	CCounter 15 MSB	Read & Write	32-bit value of captured counter 15 with memory
40114	113	0x71	CCounter 15 LSB	Read & Write	
40115	114	0x72	CCounter 16 MSB	Read & Write	32-bit value of captured counter 16 with memory
40116	115	0x73	CCounter 16 LSB	Read & Write	
40117	116	0x74	Counter Config 1	Read & Write	<p style="text-align: center;">Counter Configuration</p> +1 – time measurement (if 0 counting impulses) +2 – autocatch counter every 1 sec +4 – catch value when input low +8 – reset counter after catch +16 – reset counter if input low +32 – encoder (only for counter 1 and 3)
40118	117	0x75	Counter Config 2	Read & Write	
40119	118	0x76	Counter Config 3	Read & Write	
40120	119	0x77	Counter Config 4	Read & Write	
40121	120	0x78	Counter Config 5	Read & Write	
40122	121	0x79	Counter Config 6	Read & Write	
40123	122	0x7A	Counter Config 7	Read & Write	
40124	123	0x7B	Counter Config 8	Read & Write	
40125	124	0x7C	Counter Config 9	Read & Write	
40126	125	0x7D	Counter Config 10	Read & Write	
40127	126	0x7E	Counter Config 11	Read & Write	
40128	127	0x7F	Counter Config 12	Read & Write	
40129	128	0x80	Counter Config 13	Read & Write	
40130	129	0x81	Counter Config 14	Read & Write	
40131	130	0x82	Counter Config 15	Read & Write	
40132	131	0x83	Counter Config 16	Read & Write	
40133	132	0x84	Catch	Read & Write	Catch counter
40134	133	0x85	Status	Read & Write	Captured counter

18.2.

Bit access

Modbus Address	Dec Address	Hex Address	Register name	Access	Description
10801	800	0x320	Input 1	Read	Input 1 state
10802	801	0x321	Input 2	Read	Input 2 state
10803	802	0x322	Input 3	Read	Input 3 state
10804	803	0x323	Input 4	Read	Input 4 state
10805	804	0x324	Input 5	Read	Input 5 state
10806	805	0x325	Input 6	Read	Input 6 state
10807	806	0x326	Input 7	Read	Input 7 state
10808	807	0x327	Input 8	Read	Input 8 state
10809	808	0x328	Input 9	Read	Input 9 state
10810	809	0x329	Input 10	Read	Input 10 state
10811	810	0x32A	Input 11	Read	Input 11 state
10812	811	0x32B	Input 12	Read	Input 12 state
10813	812	0x32C	Input 13	Read	Input 13 state
10814	813	0x32D	Input 14	Read	Input 14 state
10815	814	0x32E	Input 15	Read	Input 15 state
10816	815	0x32F	Input 16	Read	Input 16 state
2113	2112	0x840	Capture 1	Read & Write	Capture counter 1
2114	2113	0x841	Capture 2	Read & Write	Capture counter 2
2115	2114	0x842	Capture 3	Read & Write	Capture counter 3
2116	2115	0x843	Capture 4	Read & Write	Capture counter 4
2117	2116	0x844	Capture 5	Read & Write	Capture counter 5
2118	2117	0x845	Capture 6	Read & Write	Capture counter 6
2119	2118	0x846	Capture 7	Read & Write	Capture counter 7
2120	2119	0x847	Capture 8	Read & Write	Capture counter 8
2121	2120	0x848	Capture 9	Read & Write	Capture counter 9
2122	2121	0x849	Capture 10	Read & Write	Capture counter 10
2123	2122	0x84A	Capture 11	Read & Write	Capture counter 11
2124	2123	0x84B	Capture 12	Read & Write	Capture counter 12
2125	2124	0x84C	Capture 13	Read & Write	Capture counter 13
2126	2125	0x84D	Capture 14	Read & Write	Capture counter 14
2127	2126	0x84E	Capture 15	Read & Write	Capture counter 15
2128	2127	0x84F	Capture 16	Read & Write	Capture counter 16
2129	2128	0x850	Captured 1	Read & Write	Captured counter 1
2130	2129	0x851	Captured 2	Read & Write	Captured counter 2

Modbus Address	Dec Address	Hex Address	Register name	Access	Description
2131	2130	0x852	Captured 3	Read & Write	Captured counter 3
2132	2131	0x853	Captured 4	Read & Write	Captured counter 4
2133	2132	0x854	Captured 5	Read & Write	Captured counter 5
2134	2133	0x855	Captured 6	Read & Write	Captured counter 6
2135	2134	0x856	Captured 7	Read & Write	Captured counter 7
2136	2135	0x857	Captured 8	Read & Write	Captured counter 8
2137	2136	0x858	Captured 9	Read & Write	Captured counter 9
2138	2137	0x859	Captured 10	Read & Write	Captured counter 10
2139	2138	0x85A	Captured 11	Read & Write	Captured counter 11
2140	2139	0x85B	Captured 12	Read & Write	Captured counter 12
2141	2140	0x85C	Captured 13	Read & Write	Captured counter 13
2142	2141	0x85D	Captured 14	Read & Write	Captured counter 14
2143	2142	0x85E	Captured 15	Read & Write	Captured counter 15
2144	2143	0x85F	Captured 16	Read & Write	Captured counter 16

19. Configuration software

Modbus Configurator is software that is designed to set the module registers responsible for communication over Modbus network as well as to read and write the current value of other registers of the module. This program can be a convenient way to test the system as well as to observe real-time changes in the registers.

Communication with the module is done via the USB cable. The module does not require any drivers.

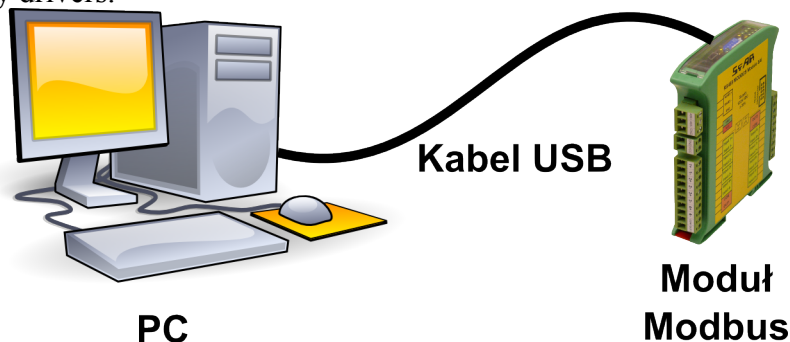

Configurator is a universal program, whereby it is possible to configure all available modules.

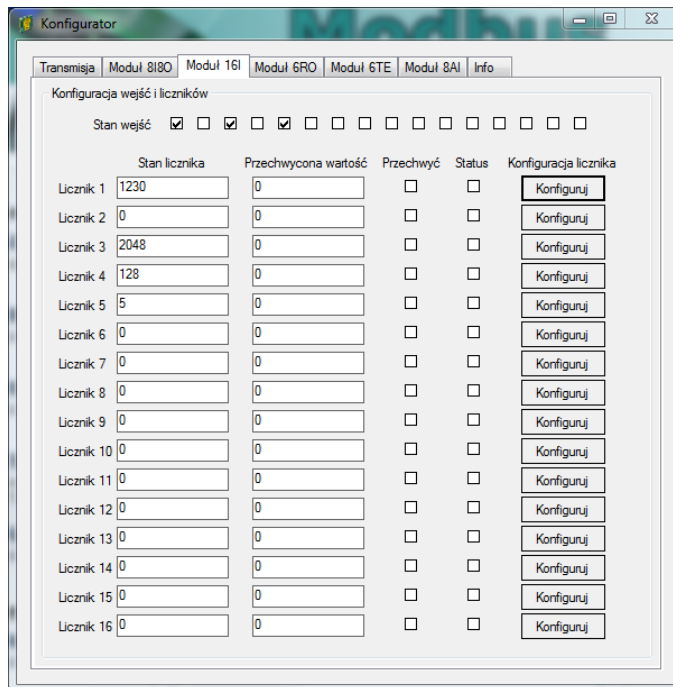

Spis treści

1. Safety rules.....	3
2. Module Features.....	3
2.1. Purpose and description of the module.....	3
2.2. Technical Specifications.....	4
2.3. Dimensions of the product.....	5
3. Communication configuration.....	6
3.1. Grounding and shielding.....	6
3.2. Network Termination.....	6
3.3. Setting Module Address in RS485 Modbus Network.....	6
3.4. Types of Modbus Registers.....	7
3.5. Communication settings.....	7
3.5.1. Default settings.....	7
3.5.2. Restore the default configuration.....	7
3.5.3. Configuration registers.....	8
4. Indicators.....	9
5. Module Connection.....	10
6. Switches.....	11
7. Modules Registers.....	12
7.1. Registered access.....	12
7.2. Bit access.....	15
8. Configuration software.....	17



Manufactured for:
Aspar s.c.
ul. Kapitańska 9
81-331 Gdynia
Poland

ampero@ampero.eu
www.ampero.eu

Tel. +48 58 351 39 89; +48 58 732 71 73



